

MOUNTING INSTRUCTIONS FOR RG6/59 CX3 - F & IEC

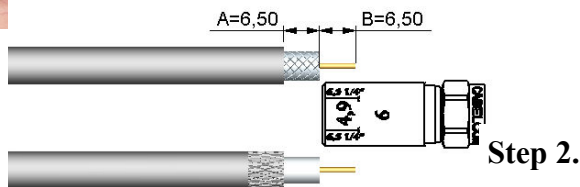

Step 1



Step 2.



Step 3.



Step 4.

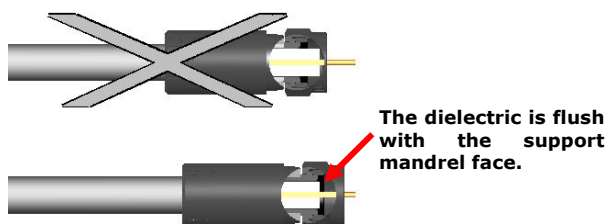
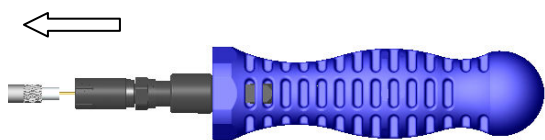

The dielectric is flush with the support mandrel face.



Step 5.

CX3 All Size compression tool
item no. 98029072



CX3 Pocket Tool 59/6
compression tool
item no. 98029070



Torque Wrench 4.5 Nm
item no. 98029080



Rubber Tool for cable
support, item no. 98028785

STEP 1: Strip the cable

We strongly recommend the use of Corning Cabelcon's pre-adjusted Rotary Cable Stripper for proper preparation of the cable. Please read the instructions for use, supplied with the tool.

Stripping dimensions

A = 6.5 mm. B = 6.5 mm.

You can use the cutting guide on the connector body to check for proper stripping dimensions.

Do not cut the braid or mark center conductor.

STEP 2: Prepare the cable

Fold exposed braid back over jacket. For "Quad shield", "Tri shield" and "Super shield" cables: Remove the outer braid and foil only. Fold back the inner braid. Leave the inner foil attached to dielectric. Make sure, that the foil is undamaged and smooth.

STEP 3: Mount the connector

Press the front part of the connector (with the built-in "tool") against the cable and turn slowly to prepare the foil to enter into the connector.

Step 4: Mount the connector.

Push the connector over the foil and allow the support mandrel to slide between the foil and braid. A mounting tool for F connector and a rubber tool for cable support can be used to keep a better grip on the connector and cable during installation. Press and turn until the dielectric is flush with the support mandrel face.

STEP 5: Compress the connector

Compress the connector using a compression tool. Please read the instructions supplied with the tool.

Make sure to use the right adjusted tool head and plunger tip. Please read the instructions supplied with the tool. Insert the connector with the cable in the tool and close the tool handle completely. Open the handle and remove the compressed connector.

Mount the connector into the tap. We recommend to tighten the nut with a torque of 4,5 Nm to ensure optimal performance of your network.

Recommended Tools	Item no.
Cable cutter - drop	98028621
Rotary cable stripper RG6/59	98501010
Rubber tool for cable support	98028785
Mounting tool	98028805
CX3 All Size compression tool	98029072
CX3 Pocket Tool 59/6 compres.	98029070
Torque wrench 4.5 Nm Hex 11mm	98029080

Please consult our Internet catalogue on www.cabelcon.dk for the latest information on Corning Cabelcon connectors and tools.

ISO 9001 certified

Distributor:

CABELCON
connectors

Corning Cabelcon ApS, Industriparken 10, DK 4760 Vordingborg
Tel: +45 55 98 55 99 · Fax: +45 55 98 55 04
E-mail: cabelcon@cabelcon.dk · www.cabelcon.dk

MOUNTING INSTRUCTIONS FOR RG6/59 CX3 BNC



Step 1

STEP 1: Strip the cable

We strongly recommend the use of Corning Cabelcon's pre-adjusted Rotary Cable Stripper for proper preparation of the cable.

Please read the instructions for use, supplied with the tool.

Stripping dimensions
A = 6.5 mm. B = 6.5 mm.

You can use the cutting guide on the connector body to check for proper stripping dimensions.

Do not cut the braid or mark centre conductor.

STEP 2: Prepare the cable

Fold exposed braid back over jacket. For "Quad shield", "Tri shield" and "Super shield" cables: Remove the outer braid and foil only. Fold back the inner braid. Leave the inner foil attached to dielectric. Make sure, that the foil is undamaged and smooth.

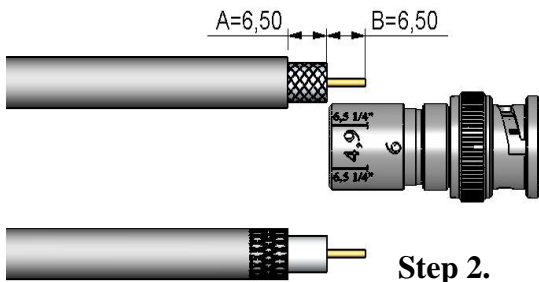

Step 2.

STEP 3: Mount the connector

Push the connector over the foil and allow the support mandrel to slide between the foil and braid.

A rubber tool for cable support can be used to keep a better grip on the cable during installation. Press and turn until the connector is in place (you can feel the mechanical stop).

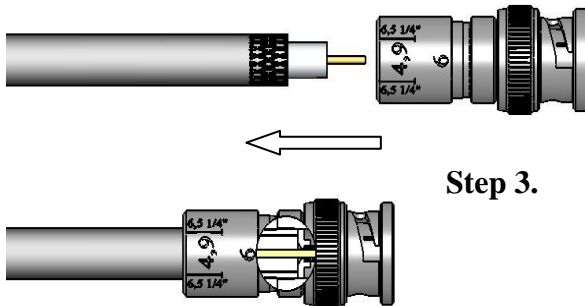

Step 3.

Step 4. Compress the connector

Compress the connector using the CX3 All Size compression tool. Make sure to use the right adjusted tool head with the plunger tip for BNC (marked "B") installed.

Please read the instructions supplied with the tool.

Insert the connector with the cable in the tool and close the tool handle completely. Open the handle and remove the compressed connector.



Step 4.

CX3 All Size compression tool
item no. 98029072

Recommended Tools	Item no.
Cable cutter - drop	98028621
Rotary cable stripper RG6/59	98501010
Rubber tool for cable support	98028785
CX3 All Size compression tool	98029072
CX3 Pocket Tool for BNC	98029074
Installation tool for BNC conn.	98028796

Please consult our Internet catalogue on www.cabelcon.dk for the latest information on Corning Cabelcon connectors and tools.



Installation Tool for BNC connector
item no. 98028785

ISO 9001 certified

Distributor:

CABELCON
connectors

Corning Cabelcon ApS, Industriparken 10, DK 4760 Vordingborg
Tel: +45 55 98 55 99 · Fax: +45 55 98 55 04
E-mail: cabelcon@cabelcon.dk · www.cabelcon.dk